



THE TRI-CON SERIES

METAL SEATED TRIPLE OFF-SET



ZWICK ARMATUREN GMBH: Maximum performance with Know-How “MADE IN GERMANY”

This valve demands a high level of expertise and a high quality of machining. With over 20 years of experience in research, development and manufacturing we ensure the TRI-CON series will meet or exceed the specifications required by the industry standards.



Within our standard range are mono flanged bodies according to API 609 and double flanged bodies according to ISO 5752, B16.10 and DIN EN 558 as well as butt weld valves



The Company's Quality Assurance is certified to ISO 9001:2000, but this is not our final goal. The sealing members being the laminated seal ring and the solid seat, are manufactured in stainless steel. Consequently, the TRI-CON valve has become one of the most widely used valves in the market.

The valve is widely proved in high demanding industries: from oxygen up to exhausted gases and superheated steam and also in widely used chemical industry processes.

The valve is used in the petrochemical and chemical industry for process and control providing excellent flow characteristics. The sealing design eliminates breakaway torques.



The capability of Zwick Armaturen GmbH includes standard process valves of the TRI-CON Series as well as a wide range of special valves.

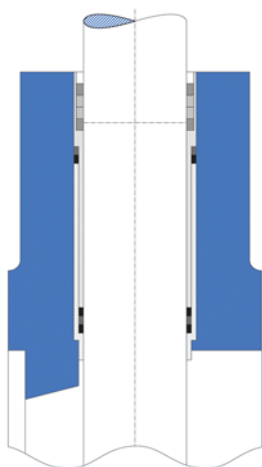

Zwick Armaturen has designed a zero leakage bushing (patented) that prevents line media from penetrating into the bushing cavity. This design has been proven in the severest of applications where other designs have failed due to fouling or corrosion of the bushing and shaft.



The standard shaft sealing meets the requirements of the emission according to "TA Luft II"

This high tech construction meets the requirements of firesafe (API and BS), "TA Luft II" and of tightness in both flow directions under full classification conditions.

We are able to offer outstanding technical support and service to meet your special valve requirements. Quick delivery, competitive pricing and full customer service are additional advantages of our company.



The Zwick Armaturen Company
- In the center of Europe

Our quality is your benefit. According to this principle we do our utmost to satisfy your requests. Due to continuous development and research we guarantee that we are your partner now and for the future.

Considered Standards:

Calculation:

- TRD 110, DIN 3840
- ASME SEC. VIII
- ASME SEC. III
- ANSI B31.1
- ANSI B31.3
- API 609

Face to Face dimensions:

- DIN EN 558
- ISO 5752
- MSS-SP-68
- API 609

Marking:

- EN 12266
- MSS SP-25

Flanged Connection:

- DIN 2501
- ISO 7005
- PN 10,16,25,40,64,100
- ANSI B16.5
- CL 150-300-600
- API
- MSS SP-44
- CL 150-300-600

Testing:

- Leaking rate according to
- DIN EN 12266, Rate A
 - API 607, BS 6755, Rate A
 - API 598

Quality Insurance:

- DIN/ISO 9001:2000
- EN 29001

A Rotary Process Valve with superior operating characteristics

With its triple eccentric design and metal-to-metal sealing, the TRI-CON series guarantees an ideal performance.

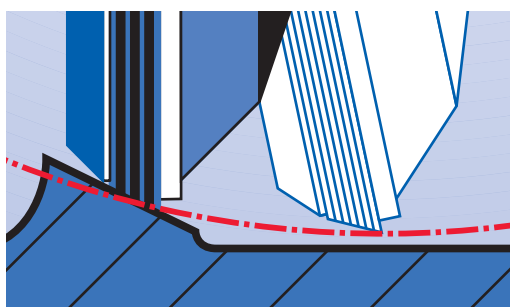

- true cone in cone sealing
- frictionless operating
- low torques
- constant closing angle on the total circumference

The operating characteristics and the tightness of the valve are not influenced by high differences in temperatures and pressure fluctuations because of the triple eccentric geometry and the valve's special features.

Maximum service life is achieved by eliminating any "rubbing" between the laminated seal around the total circumference during seating which enables a frictionless opening and closing. This guarantees full tightness and low operating torques.

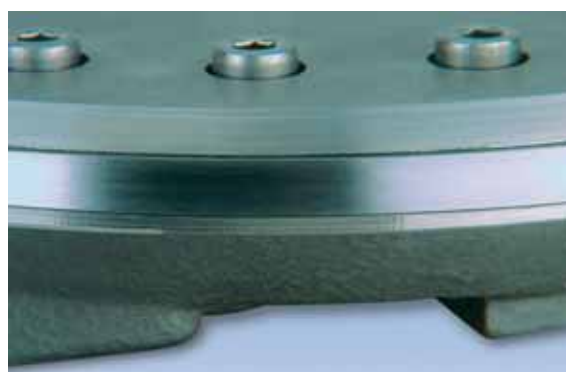

All metal laminated seal ring, for high temperature and / or aggressive applications.

The bi-directional tightness and the frictionless closing are important advantages.

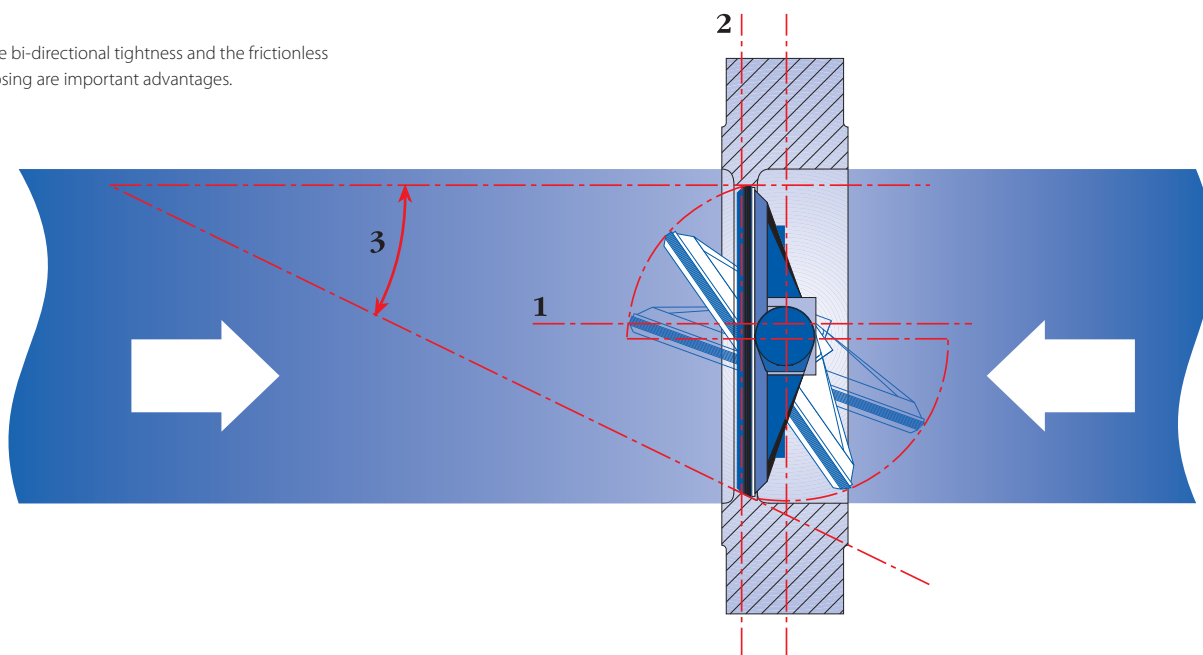

Range of applications

The Zwick Armaturen Company TRI-CON valve meets the requirements of severe service conditions where continuing reliability and tightness is of the highest importance.



Mineral Oil

- On- and Off-Shore
- Refineries
- Storage and Transport
- Flammable Materials

Chemical Industry

- Steam
- Hot Water
- Process
- Storage and Transport

Gas Industry

- Oxygen
- Natural Gas
- Storage and Transport

Power Stations, District Heating

- Steam
- Hot Water
- Process

Steel Industry

- Waste Gases
- Cooling Water

Sugar Industry

- Steam
- Hot Water
- Process

Paper and Cellulose Industry

- Steam
- Hot Water
- Process

Family of Body Styles

The right housings for your application.



Model A/L

Lugged Type
API 609 T2/
DIN EN 558

- Compact design
- DN50-900
- PN10-100
- 2" - 36"
- ANSI 150-900



Model S

Buttweld S1

- No flange tightness problems
- DN80-1500
- PN10-100
- 3" - 60"
- ANSI 150-600



Model D/I

Double Flange
ISO 5752/F16

- World-Wide standard
- DN50-1800
- PN10-100
- 2,5" - 72"
- ANSI 150-900



Model F

Double Flange
DIN EN 558/F4

- Simple mounting
- DN80-1600
- PN10-100
- 3" - 63"



Model B

Double Flange
ANSI B16.10

- Gate valve replacement
- 3" - 60"
- ANSI 150-600



Model CF

Double Flange
DIN 558/F4

- DN50-1600
- PN10-40
- 2" - 63"

A proven design with EXCELLENT CHARACTERISTICS

Special characteristics

The self-centering disc:

The construction guarantees the optimal position of the laminated seal against the seat. Jamming due to thermal expansion is eliminated.

Torque transmission using keys

The disc is keyed to the shaft not pinned, providing balanced torque transmission and eliminating the danger of pins shearing off.

Ideal lamination and disc design

The strong disc with its elliptical supporting surface offers the best fixing of the lamination. Bubble tightness is given as a result of the special machining of the lamination.

Supporting bearing bushings

The optimal position of the bearing reduces the risk of the shaft bending. This guarantees bi-directional tightness at maximum differential pressure.

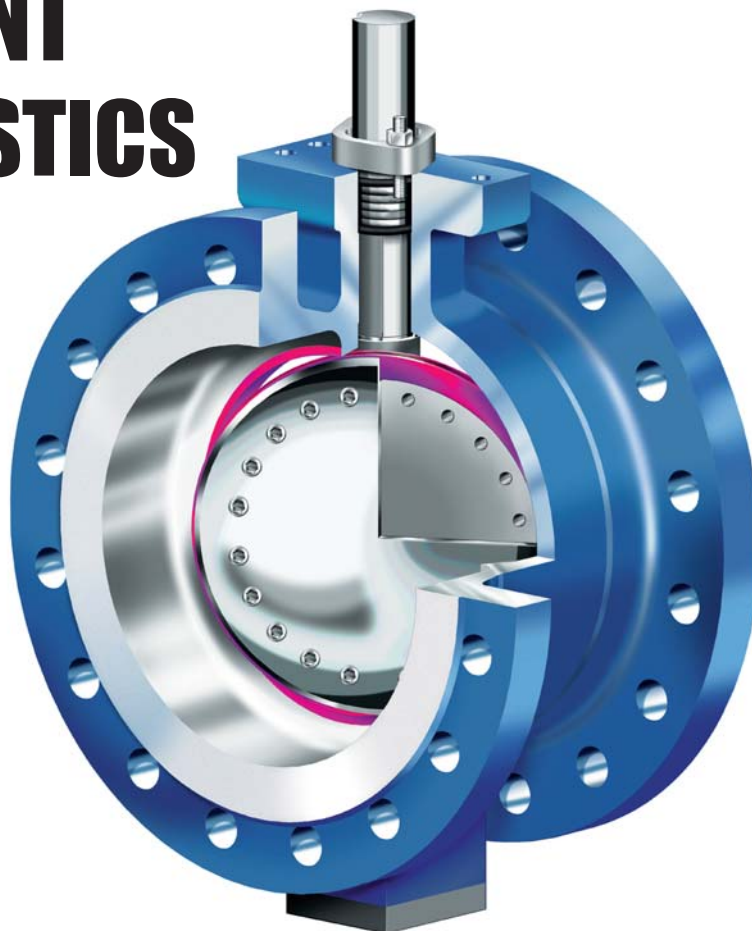

General characteristics

- Triple eccentric design
- Metal seating
- Pressure classes according ANSI 150/300/600/900 and DIN PN 10/16/25/40/64/100
- Full bi-directional shutoff as per API 598 and/or DIN EN 12266
- Temperature range -320°F up to +1022°F (-196°C up to +650°C) Additional requirements mutual agreement
- Size range 2" - 72" (DN 50-1800) Special requirements by mutual agreement
- Friction free opening and closing
- Vacuum tight
- Laminated seal and seat made of stainless steel
- Anti blow-out shaft API 609
- Steel casting, stainless steel, special alloys
- Fire-safe acc. to BS 6755 and API 607 4th ed. for both flow directions
- Special customer requirements on request
- Fugitive emission control acc. to "TA-Luft II"